



i IMPORTANT! The installation instructions contained in this manual should only be carried out by a qualified technician.

INSTALLATION / USER MANUAL

ⓘ IMPORTANT! TRANSPORTING THE CLIENT WITHIN A WHEELCHAIR FITTED WITH A MATRx BACK IN A MOTOR VEHICLE

The following guidelines should be made available to all parties who are responsible for the transportation of the client, such as schools and transport providers.

Wherever practicable the client should be transferred out of the wheelchair into a vehicle seat and use a lap and diagonal seat belt or an appropriate child safety seat.

The MaTRx back has been dynamically tested and meets the requirements of ISO 16840-4 and Section 20, ANSI/RESNA WC/Volume 4 "Wheelchair Seating Systems for Use in Motor Vehicles". A Surrogate Wheelchair Base (SWCB) and a Hybrid III Midsize-Adult Male Anthropomorphic Test Device were used in a forward facing frontal impact test. The SWCB was secured by a four-point, strap type wheelchair tie-down and the occupant restraint was a vehicle anchored lap and diagonal occupant restraint system.

MaTRx backs should only be used in conjunction with wheelchairs that comply with the performance requirements of ANSI WC19 or ISO 7176-19.

Before Entering the Vehicle Check the Following:

MaTRx Back - must be securely fastened into the wheelchair as described in the user manual.

Posture Belts & Harnesses - should remain fitted during transportation, although they are designed to provide postural support only, they are not intended for safety during transportation.

Head Support - must be securely fitted and correctly adjusted close to the rear of the client's head during transportation, in order to reduce the risk of whiplash injuries.

The Wheelchair Tie-down and Occupant Restraint System (WTORS)

- **Wheelchair Tie-down** - The wheelchair must be securely tied down within the vehicle, in a forward facing position, in accordance with the wheelchair and tie-down manufacturers instructions.
- **Occupant Restraint** - A suitable occupant restraint system must also be fitted in accordance with the manufacturer's instructions. A minimum is a lap and diagonal belt (lap belts on their own are not suitable). Restraints that loop over the shoulder and anchor to the vehicle floor should be avoided where possible, as they can cause a heavy downward load through the client during an impact, the preferred type anchor above and behind the shoulder as with a car seat belt. The lap section of the belt should fit snugly over the pelvis of the client and should not be able to ride up to the abdominal area. The upper torso section of belt should be in contact with the client's chest and fit over the shoulder(s), while not cutting into the neck or slipping off the shoulder(s).

Note: If the wheelchair and MaTRx back are to be transported unoccupied, the wheelchair should be tied down with suitable equipment according to the manufacturer's instructions. If the equipment is to be dismantled for transportation, ensure that all parts are secured safely within the vehicle.

Table of Contents

- 1.0 Hardware Kit Contents
- 2.0 Tools Required
- 3.0 Before Installation - Important
- 4.0 MaTRx-PB Installation Instructions
- 5.0 Disengaging the MaTRx-PB
- 6.0 Removing the Cover/Care Instructions
- 7.0 Head/Neck Support Installation (Optional)
- 8.0 One-Hand Cord Release Mechanism (Optional)

SAFETY SYMBOLS:

Proper set-up and safe use of your Matrix-PB Back depends on your own good judgement and common sense, as well as that of your provider, caregiver and/or health professional. The following symbols are used throughout this manual to identify warnings, cautions and important notes. It is very important that you read and understand them completely.

 **CAUTION!** Failure to heed the cautions in this manual may result in damage to your MaTRx Seating product.

 **WARNING!** Failure to heed the warnings in this manual may result in personal injury.

 **IMPORTANT!** Important information to remember during installation and set-up of you MaTRx Seating product.

 **IMPORTANT!** Please refer to the Wheelchair Owners/ Operators Manual for additional safety information, warnings and cautions related to the operation of your wheelchair.

1.0 Hardware Kit Contents

- 2 - Back Mounting Plates
- 2 - Cane Clamps
- 2 - Cane Inserts* (7/8" (22mm))
- 6 - Depth/Recline Adjustment Screws
- 6 - Cane Clamp Screws
- 2 - Cane Clamp Nut Plates
- 4 - Long Mounting Pins (optional)

*Note: 3/4"(19mm) cane inserts are available from Motion Concepts upon request.

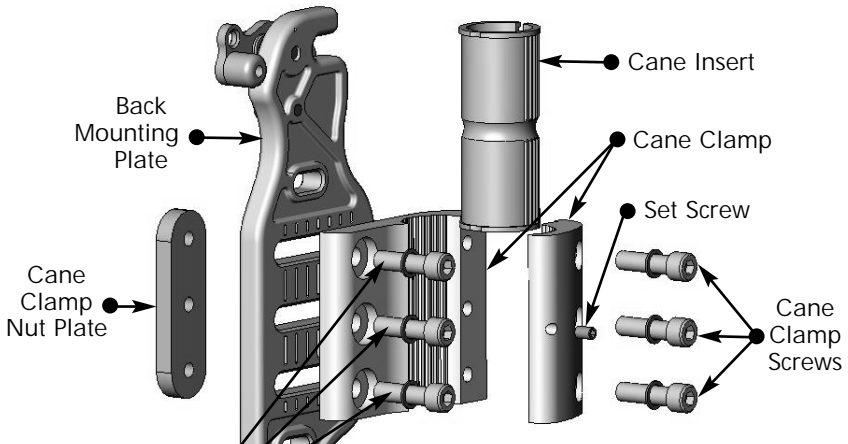

De

! PLEASE NOTE

If any of the above hardware is missing or misplaced, please contact our Customer Service Department and arrangements will be made to send you the necessary replacements.

Canada: 866-748-7943

USA: 888-433-6818

2.0 Tools Required

Wrenches: 7/8" (22mm)
Allen Keys: (provided)
Utility Knife/Scissors

Phillips Screwdriver
Tape Measure/Ruler

3.0 Before Installation - Important!

Weight Capacities:

The Mounting Plates are shipped pre-assembled on the Cane Clamps in the *rearmost* mounting configuration. This maximizes the seat depth on the wheelchair seat (up to a maximum 2.5" (64mm) rearward offset - see **Figure 1** below).

By changing the orientation of the Mounting Plates on the Cane Clamps, the assembly can be reconfigured* to provide a more *forward* mounting position for the back if desired (up to a maximum 2.5" (64mm) forward offset - see **Figure 2**)

Note: Each mounting plates is also designed to provide 1.5" (38mm) of fore and aft adjustment relative to the cane clamp

*To reconfigure a mounting plate/cane clamp to the forwardmost orientation:

- detach the Mounting Plate from the Cane Clamp (3 screws);
- Rotate the Cane Clamp 180° and re-fasten it to Mounting Plate;
- Install Cane Clamp as illustrated in **Figure 2**.



PLEASE NOTE

When establishing the mounting position for the MaTRx-PB, ensure the stability of the wheelchair is not compromised.

Adjusting the forward and aft position of the backrest will alter the user's center of gravity within the wheelchair. A recessed back position can significantly reduce the rearward stability of the wheelchair. Similarly, a more forward back position will reduce the wheelchair's forward stability.

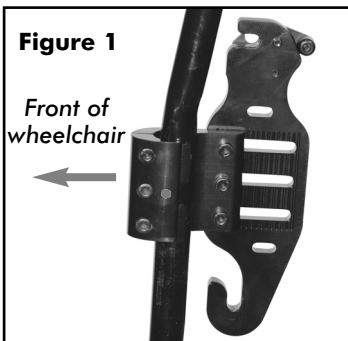

Mounting Plate in the rearmost back position (maximized seat depth).

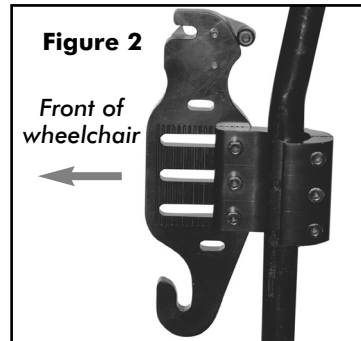

Mounting Plate in the forward most back position.

3.0 Before Installation - Important!

Acommodating Different Sized Back Post:

- ◆ 1" (25mm) back post - Cane clamps are installed without plastic inserts.
- ◆ 7/8" (22mm) back post - Requires 7/8" (22mm) plastic inserts (provided)
- ◆ 3/4" (19mm) back post - Requires 3/4" (19mm) plastic inserts*

*Note: 3/4" (19mm) inserts are available from Motion Concepts upon request.

! PLEASE NOTE

On some wheelchairs, there may be an uneven seam along the back posts where a smaller diameter tube is inserted into a larger diameter tube. If the Cane Clamps must be mounted over this seam, the plastic inserts may be cut in half to allow the clamp to fasten securely onto the back posts (see Figure 4).

Figure 4

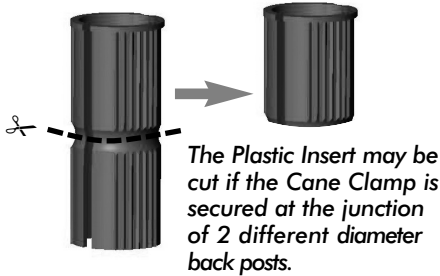
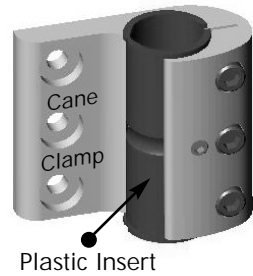

Figure 3



HELPFUL HINT

Spray a small amount of hairspray on the back canes and on the inside of the plastic inserts to create a secure 'no-slip' bond.

NOTE: For wheelchairs with short back canes, it may be necessary to install **Posture Back Cane Replacements** (PBCR's). The PBCR's are designed to replace existing push handles or cane extensions on standard 1" (25mm) back posts. The Cane Clamps can be mounted directly onto the replacement back canes in order to allow proper installation of the MaTRx-PB. Cane Replacements are available from Motion Concepts (**part#-TRX2810**).

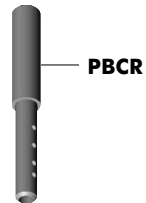

4.0 MaTRx-PB Installation Instructions

⚠ WARNING! The installation hardware provided is high strength and tested for durability. **DO NOT** substitute hardware. Use only the hardware supplied.

- 1 Remove existing wheelchair back upholstery (if applicable).
- 2 Establish the desired Mounting Plate set-up/configuration for the user (per **Section 3.0**).
- 3 Loosen Cane Clamp screws (x3) and loosely install the cane clamp (with mounting bracket) onto each back post. (*Install plastic inserts if required*).
- 4 Starting on one side, position the Cane Clamp at the desired height on the back post and tighten the clamp screws enough to hold it in place. (*Clamps and set screws will be fully tightened after the back is installed and all final adjustments have been made.*)
- 5 From a fixed point on the wheelchair (e.g. seat frame) measure the exact height of the *installed* Cane Clamp assembly, and install the second Cane Clamp at the same height on the opposite back post - see **Figure 5** below. Ensure the Cane Clamps/Mounting Plates are mounted parallel with each other.

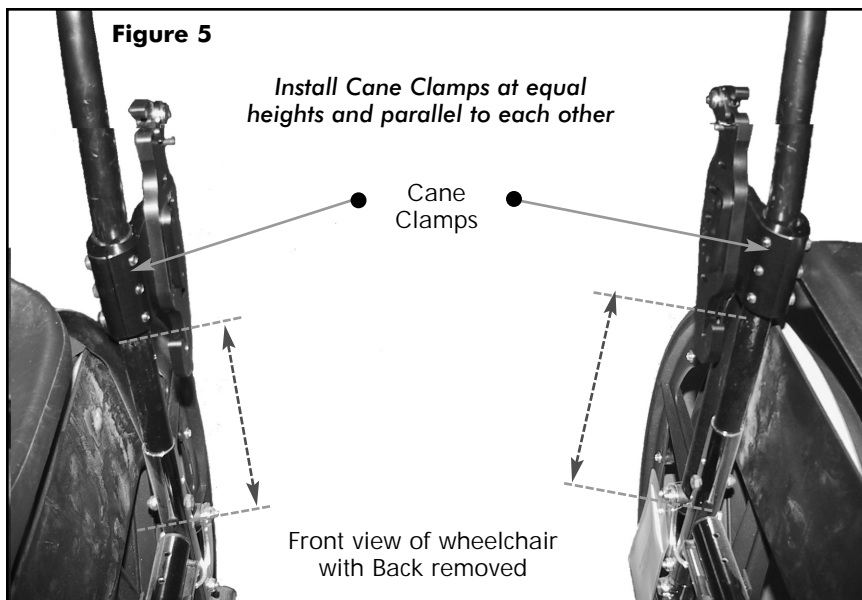

4.0 MaTRx-PB Installation Instructions

! PLEASE NOTE

Additional upper and lower adjustment slots are provided on the Mounting Plate to allow alternate mounting heights if obstacles are encountered. Using these Alternate Mounting Slots will increase or decrease the back height by 7/8" (22mm). (**note:** these alternate slots will limit the range of available depth and/or recline angle adjustment).

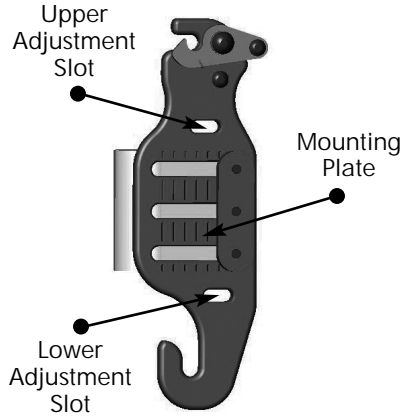

- 6 To install the MaTRx-PB onto the mounting plates:
 - Step 1: Slide the lower mounting pins into the hooked slots at the bottom of each mounting plate (see **Figure 6**).
 - Step 2: With the lower pins in place, lock/snap the upper mounting pins into the latch mechanism at the top of the mounting plates.

Figure 6



4.0 MaTRx-PB Installation Instructions

7 Mounting Pin Configurations/ Set-Up:

! PLEASE NOTE

Our standard MaTRx-PB backs are available in 3 different widths (16" (41cm); 18" (46cm); and 20" (51cm)). Two sets of Mounting Pins are supplied with every MaTRx-PB (**standard pins and long pins**). Each backrest is factory assembled with standard mounting pins. Standard pins provide sufficient adjustability to install the Matrix-PB onto most typical wheelchair back canes, and are able to compensate for back cane widths up to 1" (25mm) narrower than the actual back width. However, long pins may be required in situations where the wheelchair seat frame (including back canes) is wider than the actual MaTRx-PB back width. The long pins will accommodate a wider base seat size up to 1" (25mm) wider than the actual back width.

Example: for a 16" (41cm) MaTRx-PB:

- 15" (38cm) wheelchair seat frame (back cane) width = **standard pins**
- 16" (41cm) wheelchair seat frame (back cane) width = **standard pins**
- 17" (43cm) wheelchair seat frame (back cane) width = **long pins**

Note: when the narrowest setting is used for the back, the depth/recline range will be less than in wider positions.

MaTRx-PB
(Rear View)



! PLEASE NOTE

Extended Mounting Pins* (EMP) are available (sold separately) to allow interfacing of our PB-elite backs onto wheelchair seat frames up to 2" (5cm) wider than the actual back width.

* **Note:** EMP's are only for use with our standard back sizes (for up to 300lb (136kg) weight capacity); EMP's are not recommended for use in Tilt applications.

4.0 MaTRx-PB Installation Instructions

8 Mounting Pin Adjustment:

- i) With the back secured in place on the wheelchair, determine the amount of adjustment required for each mounting pin (see below).
- ii) Remove the backrest from the wheelchair and use a wrench to loosen the flange nut on each pin that requires adjustment. (If necessary, replace the standard mounting pins with long mounting pins).
- iii) Adjust the mounting pin depth (clockwise to shorten/counter-clockwise to lengthen) so that a minimum gap of 1/8" (3mm) exists between the top of the pin and the mounting plate. Re-tighten each flange nut to secure the pins in place. (ensure pins do not rotate when tightening the flange nuts- **NEVER** use locite on mounting pin hardware).

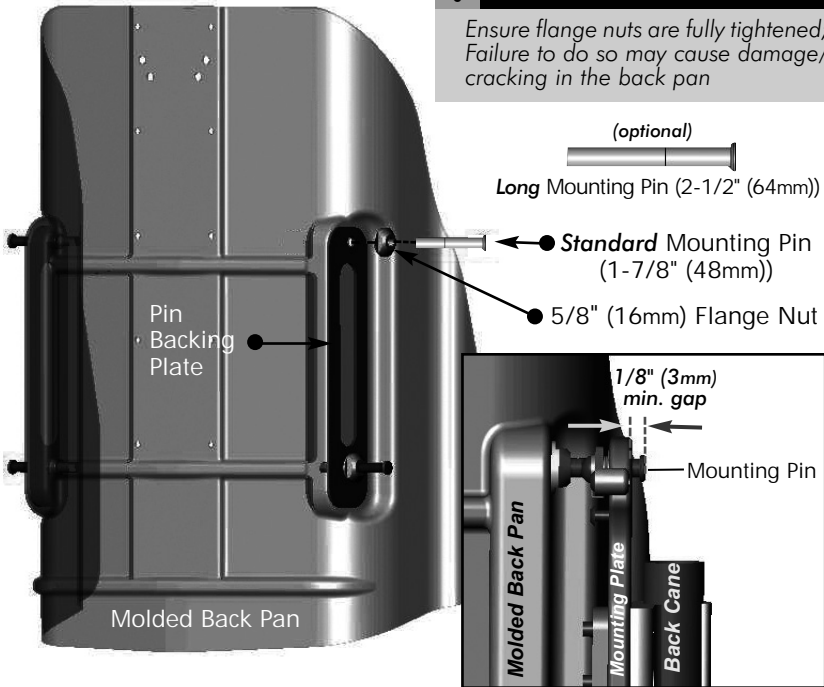

! CAUTION! Improper pin set-up may cause damage to the back pan and/or the mounting plates. Ensure sufficient spacing is provided b/w the mounting plates & the mounting pins (a min. gap of 1/8" (3mm) is recommended).

4.0 MaTRx-PB Installation Instructions

- 9 Verify that the overall fit and alignment of the back is correct (make adjustments as needed).
- 10 Fully secure the Cane Clamp Screws onto both back posts, and tighten the set screws to ensure the mounting plates do not slip or rotate.
- 11 To best determine the optimal depth & recline settings for the back, the user should be seated in the wheelchair. While seated, loosen the depth/recline screws on the mounting plates and adjust the back to the desired depth and recline angle. Re-tighten all screws to lock the back in position. Ensure that the depth/recline adjustment for the back is made symmetrically* on the left & right mounting plates.

! PLEASE NOTE

The vertical score lines on the mounting plates are designed as a point of reference to assist with symmetrical mounting (see image below). Since the back can be mounted in a rotated (reclined) position if desired, it will not always be mounted parallel with these vertical lines.

*Use score lines to make symmetrical adjustments on the left and right mounting plates.

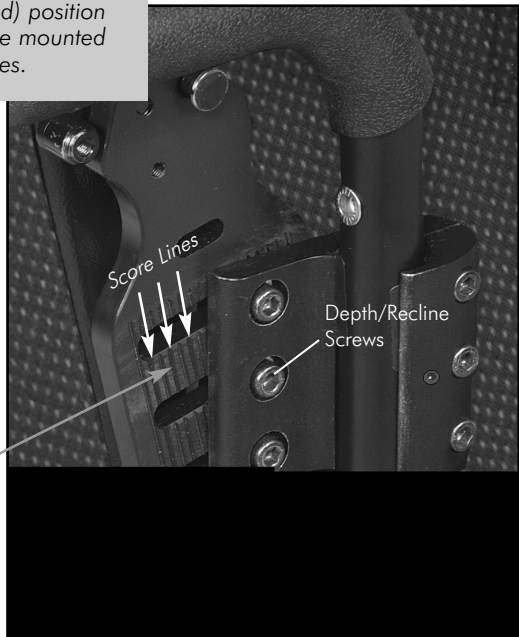

6.0 Removing the Cover/Care Instructions

The MaTRx-PB cover can be removed for laundering or providing access to the inside of the back for modification.

Open the zipper at the top and carefully remove the cover by releasing the velcro hook & loop fasteners along the sides of the back shell.

General Care and Cleaning: The cover may be easily wiped down with a damp cloth when necessary. For specific laundering directions, please follow the washing instructions provided with the cover.

7.0 Head/Neck Support Attachments (Optional)

All MaTRx-PB backs contain a built-in Headrest Plate which can be used for attaching optional Head and Neck Supports.

Two sets of headrest clamp mounting holes are provided in order to install most standard types of headrests (see **Figure 8** below). If required, additional holes may be drilled into the back pan and headrest plate to mount the necessary hardware.

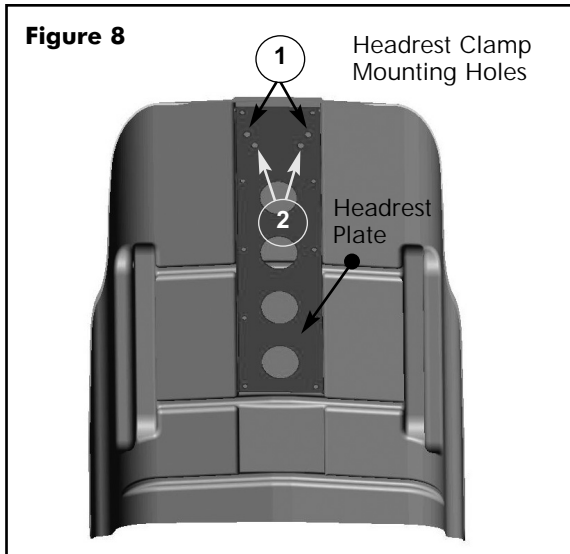

7.0 Head/Neck Support Attachments

Instructions for installing a Headrest Clamp:

- 1 Open (pull down) cover and determine the appropriate set of mounting holes for the Headrest Clamp (drill new holes if necessary).
- 2 Close the cover and carefully punch holes through the cover fabric that correspond with the determined mounting holes for the Headrest Clamp.
- 3 Open and pull down the *front* half of the cover (enough to access the appropriate mounting holes on the Headrest Plate).
- 4 Place the Headrest Clamp on the outside of the back cover and push the mounting screws *inward* through the fabric and through the Headrest Plate.
- 5 Secure (bolt) the Headrest Clamp into place (*see note below) and close the cover.

Headrest Clamp Mounting Holes

! PLEASE NOTE

The Headrest Plate is recessed into the Back Pan to prevent hardware from protruding into the back cushion. Please ensure that the hardware from the headrest clamp does not extend beyond this recessed area.

Headrest Plate

Back Pan

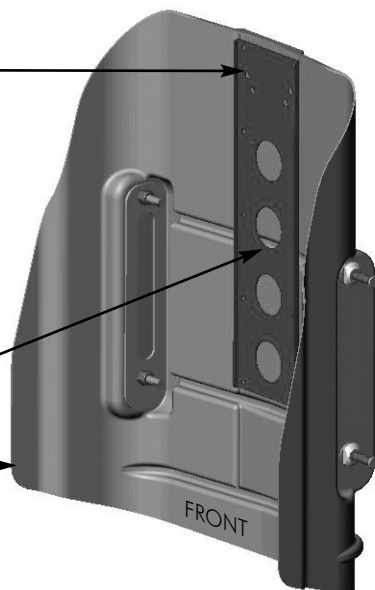

! WARNING! Headrests that have been fitted onto the MaTRx-PB back are **not** intended for use during transport, and will not provide adequate support in the event of a crash. Users of wheelchairs should be transferred into appropriate seating in vehicles for transportation and use be made of the restraints made available by the auto industry.

8.0 One-Hand Cord Release Mechanism (Optional)

Installation Instructions:

1. Thread the **Nylon Cord** through the holes in the latch mechanism at the top of the left and right mounting plates (see image **A.** below.)



2. Install the **Cord-Lock** mechanism onto the cord (see image **B.** below). Press the button to open the lock mechanism and slide the two open ends of the nylon cord through the opening.

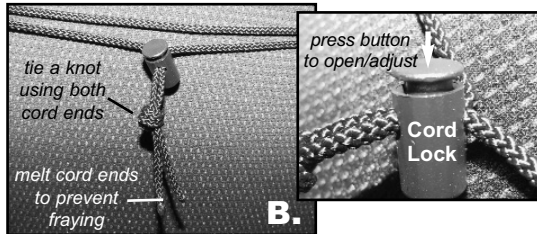

3. With the back properly installed on the wheelchair, adjust the cord length so that it hangs at approximately a **35-45° angle** along the back pan (*this allows the release mechanism to operate more effectively*). If necessary, **cut/remove excess cord** to eliminate any risk of entanglement. Once adjusted, combine the loose cord ends into a single knot to prevent the cord-lock from slipping. (*Note: if the cord length was modified, carefully melt the ends of the cord to prevent fraying*)

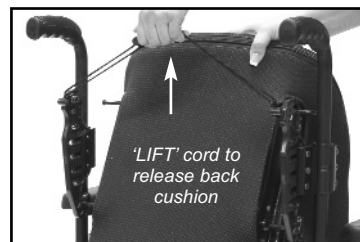
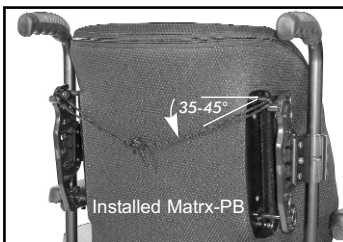

WARRANTY

Every MaTRx-PB back is carefully inspected and tested to provide optimum performance. Each back is guaranteed to be free from defects for a period of 24 months from the date of purchase, provided normal use. Should a defect in materials or workmanship occur within 24 months of the original date of purchase, Motion Concepts will, at its option, repair or replace it free of charge. This warranty does not apply to punctures, tears or burns, nor to the removable cushion cover.

The original back must be returned to the dealer and will become the property of Motion Concepts as a condition of processing the warranty claim. All warranty claims must be made through the dealer where the cushion was purchased. Except for express warranties made herein, all other warranties of fitness or use for a particular purpose are excluded. There are no warranties that extend beyond the warranties provided above. Remedies for breach of this warranty are limited to repair or replacement of goods. In no event shall damages for breach of any warranty include any consequential damages or exceed the original cost of the back.

